

11. (a) (i) For the given circuit given below, calculate the magnitude and direction of current in each battery and the total current taken from the 220 V supply mains. (12)

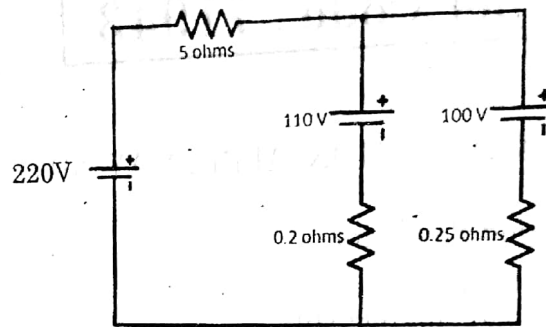

- (ii) A coil takes a current of 6A when connected to a 24 V d.c supply. To obtain the same current with a 50Hz a.c. supply, the voltage required is 30 V. Calculate
- (1) the inductance of the coil
 - (2) the power factor of the coil. (4)
- Or
- (b) Explain the construction and working of Dynamometer type watt meter. Mention its merits and demerits. (12 + 4)
12. (a) (i) With a neat diagram explain the construction and working of D.C. Generator. (12)
- (ii) Derive the EMF equation. (4)
- Or
- (b) Explain the construction and working of single phase transformer. (16)
13. (a) (i) Explain the working of PN junction diode and mention its applications. (8)
- (ii) Draw the circuit diagram for full wave rectifier and explain its working. (8)
- Or
- (b) For the CE transistor configuration, draw the circuit and explain the input and output characteristics. (16)
14. (a) (i) Prove the Boolean identity $AB + A\bar{B} + \bar{A}B = A + B$. (4)
- (ii) Explain the working of JK and D flip flops. (12)
- Or
- (b) With a neat diagram explain the working of 4 bit binary ripple counter. (16)
15. (a) Short notes on
- (i) Microwave communication. (8)
 - (ii) FAX. (8)
- Or
- (b) Draw the block diagram and explain the fiber optic communication. Mention its applications. (12 + 4)

PART B — (5 × 16 = 80 marks)

11. (a) For the give circuit, determine the current in 5 Ω resistor.

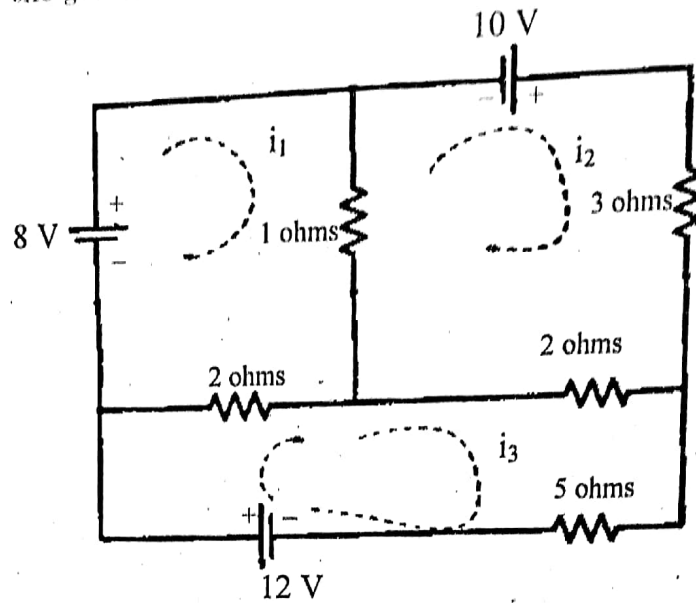

Or

- (b) (i) Explain the construction and working of an Energy Meter. (12)
 (ii) How do you extend the range of an ammeter and a voltmeter? (4)
12. (a) (i) With a neat diagram explain the construction and working of D.C. Motor. (12)
 (ii) Derive the torque equation. (4)

Or

- (b) Explain the construction and working of single phase Induction Motor. (16)
13. (a) (i) Explain the working of Zener diode and mention its applications. (8)
 (ii) Draw the circuit diagram for half wave rectifier and explain its working. (8)

Or

- (b) Explain the operation of NPN and PNP transistors. (16)
14. (a) (i) Prove the following Boolean identity

$$ABC + AB\bar{C} + \bar{A}BC = B(A + \bar{C})$$
 (4)
 (ii) Draw the full adder circuit. Explain with Truth Table and expression. (12)

Or

- (b) With a neat diagram explain the working of binary ladder network for digital to analog conversion. (16)

15. (a) Describe the principle of Amplitude and Frequency Modulation. (8+8)

Or

(b) (i) Draw the block diagram and explain the working of Satellite Communication Systems. (12)

(ii) Mention its merits and demerits. (4)

Reg. No.

--	--	--	--	--	--	--	--	--	--	--	--	--	--	--	--	--	--	--	--

Question Paper Code : 57413

B.E./B.Tech. DEGREE EXAMINATION, MAY/JUNE 2016

Second Semester

Civil Engineering

GE 6252 – BASIC ELECTRICAL AND ELECTRONICS ENGINEERING

(Common to all Branches except Electronics and Communication Engineering, Medical Electronics Engineering, Biomedical Engineering, Computer Science and Engineering, Information Technology, Computer and Communication Engineering, Electrical and Electronics Engineering, Electronics and Instrumentation Engineering, Instrumentation and Control Engineering and Pharmaceutical Technology)

(Regulations 2013)

Time : Three Hours

Maximum : 100 Marks

Answer ALL questions.

PART – A (10 × 2 = 20 Marks)

1. A 50 ohm resistor is in parallel with a 100 ohm resistor. The current in 50 ohm resistor is 7.2 A. What is the value of third resistance to be added in parallel to make the total line current as 12.1 A ?
2. List the operating forces present in indicating instruments.
3. Sketch the OCC of DC shunt generator.
4. Write down the EMF equation of a transformer.
5. Draw the circuit diagram of half wave rectifier.
6. List various hybrid parameters of transistor.
7. State De Morgan's theorem.

8. What is register in digital systems ?
9. Draw the block diagram of communication system and explain its operation.
10. What is ISDN ?

PART - B (5 × 16 = 80 Marks)

11. (a) (i) A series circuit has $R = 50\text{ohms}$, $L = 13\text{mH}$, and $C = 140\ \mu\text{F}$ and is supplied with 230V , 50Hz single phase. Find (i) Impedance (ii) current (iii) power (iv) power factor of the circuit. (8)
- (ii) Two impedances $(8 + j10)\ \text{ohm}$ and $(7 + j9)\ \text{ohm}$ are connected in parallel. Find magnitude and phase angle of total impedance. Another impedance $(5 - j2)\ \text{ohm}$ is connected in series with above combination. Find overall impedance. (8)

OR

- (b) Explain the construction and principle of operation of single phase energy meter. (16)

12. (a) (i) Describe various types self excited of DC generators with their circuit layout. (8)
- (ii) Explain the characteristics of DC shunt motor. (8)

OR

- (b) Explain the tests on single phase transformer and develop an equivalent circuit from the above tests. (16)

13. (a) (i) Explain V-I characteristics of zener diode and applications with necessary diagrams. (8)
- (ii) Explain the operation of full wave rectifier with necessary diagrams. (8)

OR

- (b) Explain how you will obtain the static characteristics of common emitter configuration. (16)

14. (a) (i) List various types of logic gates with its logic symbols and truth table. List also universal gates. (8)
- (ii) Realize the logic expression $Y = (A + B) (A' + C) (B + D)$ using basic gates. (8)

OR

- (b) Explain the full adder circuit with its expressions and truth table. (16)

15. (a) What is meant by modulation ? Explain different types of analog and digital modulation techniques with neat diagrams. (16)

OR

- (b) (i) Draw the block diagram of B/W TV receiver and explain it. (8)
- (ii) Draw the block diagram of optical fibre communication system and explain it. (8)

8. What is a flip flop?
9. Differentiate analog and digital signals.
10. Define Total internal reflection.

PART B — (5 × 16 = 80 marks)

11. (a) Describe Kirchoff's laws. For the circuit shown in the figure below, determine the current through 6 Ω resistor

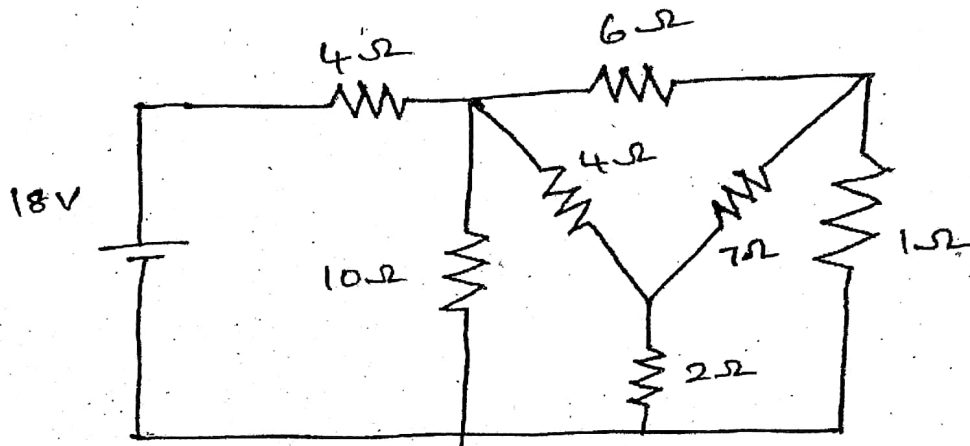

Or

- (b) (i) With the help of diagrams, explain the construction and working principle of permanent magnet moving coil instruments. Obtain an expression for its deflecting torque.
 - (ii) Explain the working principle of dynamometer type of wattmeter. Mention its disadvantages also.
12. (a) A 220-V D.C. series motor runs at 700 rpm when operating at its full-load current of 20 A. The motor resistance is 0.5 Ω and the magnetic circuit may be assumed unsaturated. What will be the speed if:
 - (i) Load torque is increased by 44%?
 - (ii) Motor current is 10 A?
 - (iii) Explain the operation and principle of a DC motor.

Or

- (b) Explain the construction of single phase transformer.

13. (a) (i) Explain the operation of Full wave rectifier.
(ii) Derive the expression for RMS voltage, current, DC power, efficiency, PIV and TUF.

Or

- (b) Explain the elementary treatment of small signal amplifier.
14. (a) (i) Realize and draw the logic diagram for the given function with minimum number of gates $\overline{A}B + ABC + A\overline{B}(B + C) + AB\overline{C}$.
(ii) Explain the operation and truth table of half adder with a neat diagram.

Or

- (b) (i) Draw and explain operation of JK flip flop.
(ii) Describe the categorization and functioning of shift registers.
15. (a) Why modulation is necessary? Write in detail about frequency modulation.

Or

- (b) Discuss the usage of satellite for long distance communication with a neat block diagram of basic satellite transponder.
-

PART B — (5 × 16 = 80 marks)

11. (a) Determine the current, power X in the 4Ω resistance of the circuit shown below : (16)

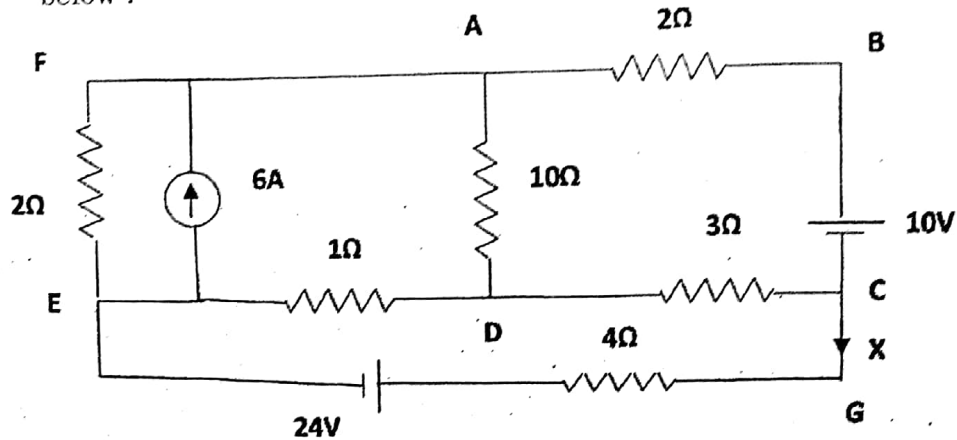

Or

- (b) Draw and explain the working principle of attraction type, repulsion type M.I. instruments and derive its deflecting torque. (16)
12. (a) With neat sketches, explain the working principle and the construction of DC motor. Also derive the torque and speed equation. (16)
- Or
- (b) (i) Derive the torque and speed equations of DC motor. (8)
(ii) Explain the construction details of single phase transformer. (8)
13. (a) Describe the working of a PN junction diode with neat diagrams. Also explain its V-I characteristics. (16)
- Or
- (b) (i) Let $V_{BB} = 10\text{ V}$, $R_B = 1\text{ M}$, $\beta = 100$, $V_{CC} = 15$, $R_L = 10\ \Omega$ in the transistor circuit, find (1) I_B (2) I_c (3) I_E . (4) V_{CE} , Neglect V_{BE} . (8)
(ii) Explain the working of zener diode and its applications. (8)
14. (a) (i) Draw the logic symbol of OR, NAND, NOT gate and explain its logic operation. (8)
(ii) Draw and explain the operation of following flip-flops, (1) RS flip-flops using NOR gate (2) D flip-flops using NAND gate. (8)
- Or
- (b) With necessary diagrams describe the operation of a 4-bit binary, ripple counter. (16)
15. (a) Describe the principle of modulation and its needs. Write the short note on amplitude modulation and frequency modulation. (16)
- Or
- (b) Describe the functional block diagram of Monochrome TV transmitter and receiver with a neat sketch. (16)

PART B — (5 × 16 = 80 marks)

11. (a) Obtain expression of power and power factor for three phase A.C. star connected balanced load circuit. (16)

Or

- (b) With diagram explain principle of operation of permanent magnet moving coil ammeter. (16)

12. (a) With diagram explain construction and operation of D.C. Motor. (16)

Or

- (b) With diagram describe construction and operation of single phase transformer. (16)

13. (a) Draw and explain characteristics of PN Junction diode. (16)

Or

- (b) Draw and explain input and output characteristics of CE – Bipolar Junction transistor. (16)

14. (a) With circuit and truth table explain working of JK Flip-Flop. (16)

Or

- (b) With circuit and timing diagram working of 4-bit asynchronous down counter. (16)

15. (a) With block diagram explain TV transmission and reception system. (16)

Or

- (b) Describe principle of operation of fax system. (16)

Reg. No. :

--	--	--	--	--	--	--	--	--	--	--	--	--	--	--	--	--	--	--	--

Question Paper Code : 57022

B.E./B.Tech. DEGREE EXAMINATION, MAY/JUNE 2014.

Second Semester

Civil Engineering

GE 6252 — BASIC ELECTRICAL AND ELECTRONICS ENGINEERING

(Common to all Branches except Electronics and Communication Engineering, Medical Electronics Engineering, Biomedical Engineering, Computer Science and Engineering, Information Technology, Computer and Communication Engineering, Electrical and Electronics Engineering, Electronics and Instrumentation Engineering, Instrumentation and Control Engineering and Pharmaceutical Technology)

(Regulation 2013)

Time : Three hours

Maximum : 100 marks

Answer ALL questions.

PART A — (10 × 2 = 20 marks)

1. State Ohm's law and its limitations.
2. Define the principle of moving iron instrument for attraction type.
3. Calculate the e.m.f generated by a 4-pole, wave-wound armature having 45 slots with 18 conductors per slot when driven at 1200 r.p.m. and the flux per pole is 0.016 Wb.
4. List out the types of single phase induction motors.
5. Define the two breakdown conditions in Zener diode.
6. Find the values of I_C , I_B and β . Transistor values are $\alpha = 0.95$, $I_E = 1$ mA.
7. Define the logic operation of AND gate with Boolean equation.

8. Prove the following Boolean identity.

$$A + \bar{A}B = A + B.$$

9. Compare analog and digital signals.

10. What are the advantages of Optical Fibre Communication?

PART B — (5 × 16 = 80 marks)

11. (a) (i) Determine the current, power in the 4Ω resistance of the circuit shown below. (10)

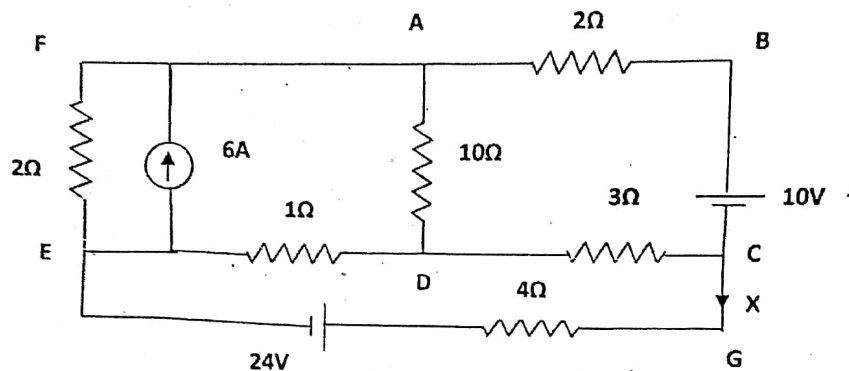

(ii) RL series circuits having a resistance of 6Ω and an inductance of 0.03H is connected across a 100V , 50Hz Supply. Calculate the phase angle between the current and the voltage, power factor. (6)

Or

(b) (i) A 15V moving-iron voltmeter has a resistance of 500Ω and an inductance of 0.12H . Assuming that this instrument reads correctly on DC. What will be its reading on AC at 15V when the frequency

- 25Hz and
- 100Hz .

(6)

(ii) Explain the principle and operation of dynamometer type Watt meter and derive deflecting torque. Write advantages and disadvantages. (10)

12. (a) (i) With neat sketches, explain the working principle and the construction of DC motor. Also derive the Torque and speed equation. (12)

(ii) A d.c shunt generator supplies a load of 7.5KW at 200V . Calculate the induced e.m.f if armature resistance is 0.6Ω and field resistance is 80Ω . (4)

Or

(b) (i) At starting the windings of a 230 V, 50 Hz, split-phase induction motor, main winding : $R = 4\Omega$, $X_L = 7.5\Omega$ and then starting winding $R = 7.5\Omega$, $X_L = 4\Omega$. Find

(1) Current I_M in the main winding

(2) Current I_S in the starting winding

(3) Phase angle between I_S and I_M

(4) Line current

(5) Power factor of the motor. (10)

(ii) Explain the principle and working of single phase transformer. (6)

13. (a) (i) Describe the working of PN junction diode in forward and reverse bias condition. (10)

(ii) Explain the operation of NPN and PNP transistor. (6)

Or

(b) (i) Let $V_{BB} = 10V$, $R_B = 1M$, $\beta = 100$, $V_{CC} = 15$, $R_L = 10\Omega$ in the transistor circuit, find

(1) I_B

(2) I_C

(3) I_E

(4) V_{CE} , Neglect V_{BE} . (8)

(ii) Explain the working of Zener diode and its applications. (8)

14. (a) (i) Draw the logic symbol of OR, AND, NOT gate and explain its logic operation. (8)

(ii) Draw a half adder using logic gates. Explain with truth table with expression of sum and carry. (8)

Or

(b) (i) Explain the operation and draw the following flip-flops,

(1) RS flip-flops using NOR gate

(2) D flip-flops using NAND gate

(3) JK flip-flops. (3 × 4 = 12)

(ii) Explain the operation of synchronous counters. (4)

15. (a) (i) Describe the principle of modulation and its needs. Short note on amplitude modulation and frequency modulation. (12)
- (ii) Give some advantages of FM over AM. (4)

Or

- (b) (i) With help of block diagram describe the working of a satellite (earth station transmitter) communication and its short note on earth station receiver. (12)
- (ii) Explain the operation of monochrome TV transmitter. (4)
-

8. An active high S-R latch has a '1' on the S-input and '0' on the 'R' input. What state is the latch in?
9. As related to amplitude modulation, what is overmodulation, undermodulation and 100% modulation?
10. Why are digital signals said to be noise immune?

PART B — (5 × 16 = 80 marks)

11. (a) (i) (1) State and explain Kirchoff's laws. (4)
- (2) A sinusoidal current wave is given by $i = 50 \sin(100\pi t)$. Determine the root mean square value. (4)
- (ii) Write short notes on moving Iron Measuring Instruments under the following headings :
- (1) Operating principle. (4)
- (2) Classification. (2)
- (3) Advantages and disadvantages. (2)

Or

- (b) (i) 3ϕ , 200 kW, 50 Hz delta connected induction motor is supplied from a 3ϕ , 440 V, 50 Hz supply system. The efficiency and power factor of 3ϕ induction motor are 91% and 0.86 respectively. Calculate :
- (1) (A) Current in each motor phase (2)
- (B) Line current. (2)
- (2) Phasor diagram of the circuit. (4)
- (ii) Find the current in the 8Ω resistor in the following circuit using Kirchoff's laws. (8)

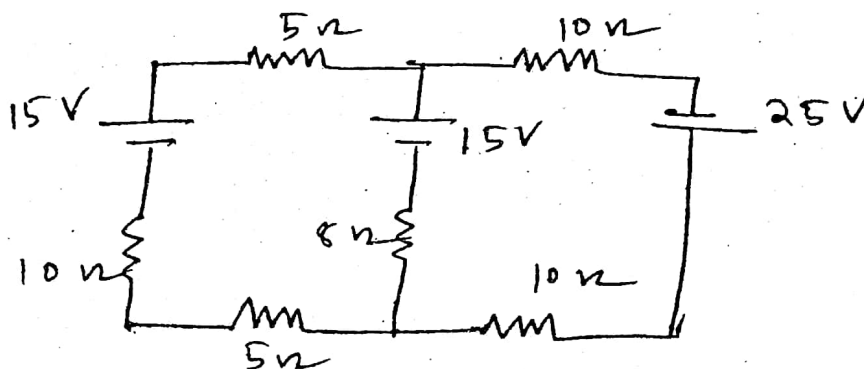

12. (a) (i) Write short notes on the types of DC machines. (8)
- (ii) With neat diagrams explain the construction and principle of operation of a single phase transformer. What are the characteristics of an ideal transformer? (8)

Or

- (b) (i) (1) Explain the basic nature of the emf induced in the armature of a d.c. machine. (4)
- (2) How can the alternating current waveform in the armature be converted into a dc waveform? (4)
- (ii) A 200 V dc shunt motor takes a total current of 100 A and runs at 750 rpm. The resistance of the armature winding and of shunt field winding is 0.1 and $40\ \Omega$ respectively. Find the torque developed by the armature. (8)

13. (a) (i) With neat diagrams explain how a voltage regulator circuit regulates the output voltage under the following conditions :

- (1) Load resistance increases. (4)
- (2) Input voltage decreases. (4)
- (ii) (1) Using the two diode analogy explain why the base-emitter junction has to be forward biased to provide collector current.
- (2) Sketch a common emitter amplifier circuit with an NPN transistor. (8)

Or

- (b) (i) (1) Explain the avalanche effect that accounts for the reverse breakdown voltage (PIV) of a diode. (4)
- (2) What is the effect on capacitance of a PN junction diode as forward and reverse bias are applied? (4)
- (ii) (1) Explain the amplifying action of a transistor. (6)
- (2) In a CE, I_B changes from $100\ \mu\text{A}$ to $150\ \mu\text{A}$ which causes a change in I_C from 5 mA to 7.5 mA. If V_{CE} is held constant at 10 V, find β_{ac} (h_{fe}). (2)

PART B — (5 × 16 = 80 marks)

11. (a) Classify surveying based on the instruments used. Discuss any two methods in detail.

Or

- (b) Discuss qualities and uses of any three building materials.

12. (a) Discuss in detail about the foundation for machinery.

Or

- (b) (i) Explain various kinds of rubble masonry with sketches. (8)
(ii) Write short notes on columns. (8)

13. (a) (i) Write briefly about the types of floorings. (6)
(ii) What are the factors to be considered and data to be collected before constructing a bridge? (10)

Or

- (b) (i) Draw the layout of thermal power plant and indicate various systems in it. (10)
(ii) Write briefly the principle of working of single acting reciprocating pump. (6)

14. (a) With relevant sketches explain the operation of four stroke petrol engine.

Or

- (b) (i) Write briefly about the fuel supply systems used in SI engines. (10)
(ii) Compare two stroke and four stroke engines. (6)

15. (a) Explain the operation of any one type of refrigeration system with the schematic line diagram.

Or

- (b) Explain Window Air-Conditioner with a neat diagram.

VITEEE



Reg. No. :

--	--	--	--	--	--	--	--	--	--	--	--	--	--	--	--	--	--	--	--

Question Paper Code : 50653

B.E./B.Tech. DEGREE EXAMINATION, NOVEMBER/DECEMBER 2017
Second Semester

Mechanical Engineering

GE 6252 – BASIC ELECTRICAL AND ELECTRONICS ENGINEERING

(Common to Mechanical Engineering (Sandwich), Aeronautical Engineering, Agriculture Engineering, Automobile Engineering, Civil Engineering, Environmental Engineering, Geoinformatics Engineering, Industrial Engineering, Industrial Engineering and Management, Manufacturing Engineering, Marine Engineering, Materials Science and Engineering, Mechanical and Automation Engineering, Mechatronics Engineering, Petrochemical Engineering, Production Engineering, Robotics and Automation Engineering, Chemical Engineering, Chemical and Electrochemical Engineering, Fashion Technology, Food Technology, Handloom and Textile Technology, Petrochemical Technology, Petroleum Engineering, Plastic Technology, Polymer Technology, Textile Chemistry, Textile Technology, Textile Technology (Fashion Technology))
(Regulations 2013)

Time : Three Hours

Maximum : 100 Marks

Answer ALL questions.

PART – A

(10×2=20 Marks)

1. State the advantages of sinusoidal alternating quantity.
2. Find the value of P_3 in the below circuit.

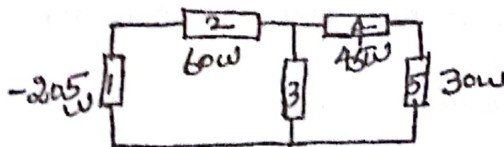

3. Draw the open Circuit Characteristics Curve (OCC) of DC generator.
4. Write the output voltage equation of single phase transformer.



5. Give difference between the half wave and full wave rectifiers.
6. List out the use of h-Parameters.
7. Prove the cumulative and associative Boolean algebra.
8. Draw the Full Adder circuit.
9. List the types of signals.
10. Mention the few advantages of satellite communication.

PART - B

(5×16=80 Marks)

11. a) Determine the branch currents in the network when the value of each branch resistance is $1\ \Omega$. (16)

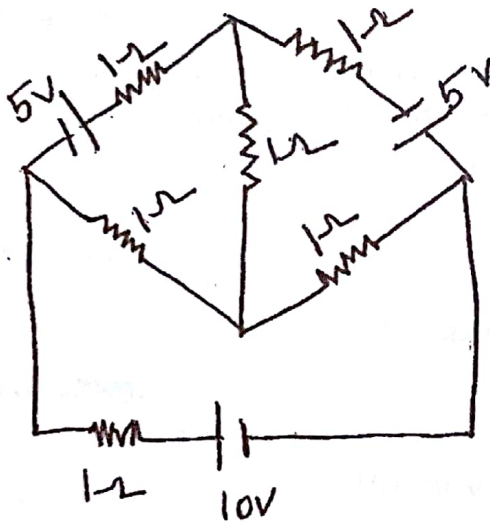

(OR)

- b) Explain the operating principle of moving coil and moving iron instruments. (16)
12. a) Explain the construction and working principle of DC generators with neat diagrams. (16)

(OR)

- b) Describe the different starting methods for single phase induction motor. (16)

13. a) Explain with neat diagram, How current flows in a PN Junction diode and also discuss the limitations in the operating conditions of PN Junction with V-I characteristics. (16)

(OR)

- b) Discuss the static characteristics (input and output) of Common Emitter (CE) Configuration of BJT. (16)

14. a) Design and explain the working of a synchronous mod-6 counter. (16)

(OR)

- b) Explain the analog to digital converter using the successive approximation technique with neat diagram. (16)

15. a) Explain the need for modulation and also compare AM with FM. (16)

(OR)

- b) i) Discuss the merits and demerits of FAX machines. (8)

- ii) Explain the working principle of microwave communication. (8)
-